

S500 PRO

Pièces détachées
Spare part list

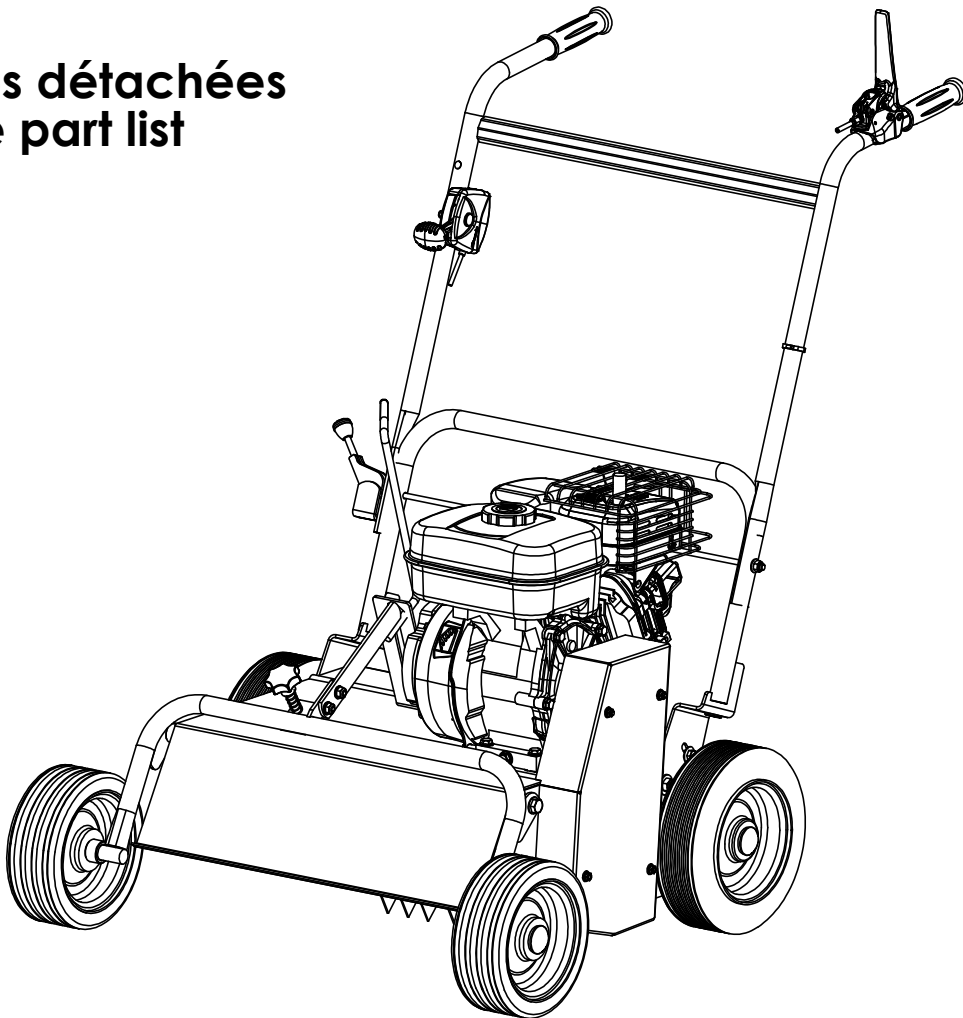

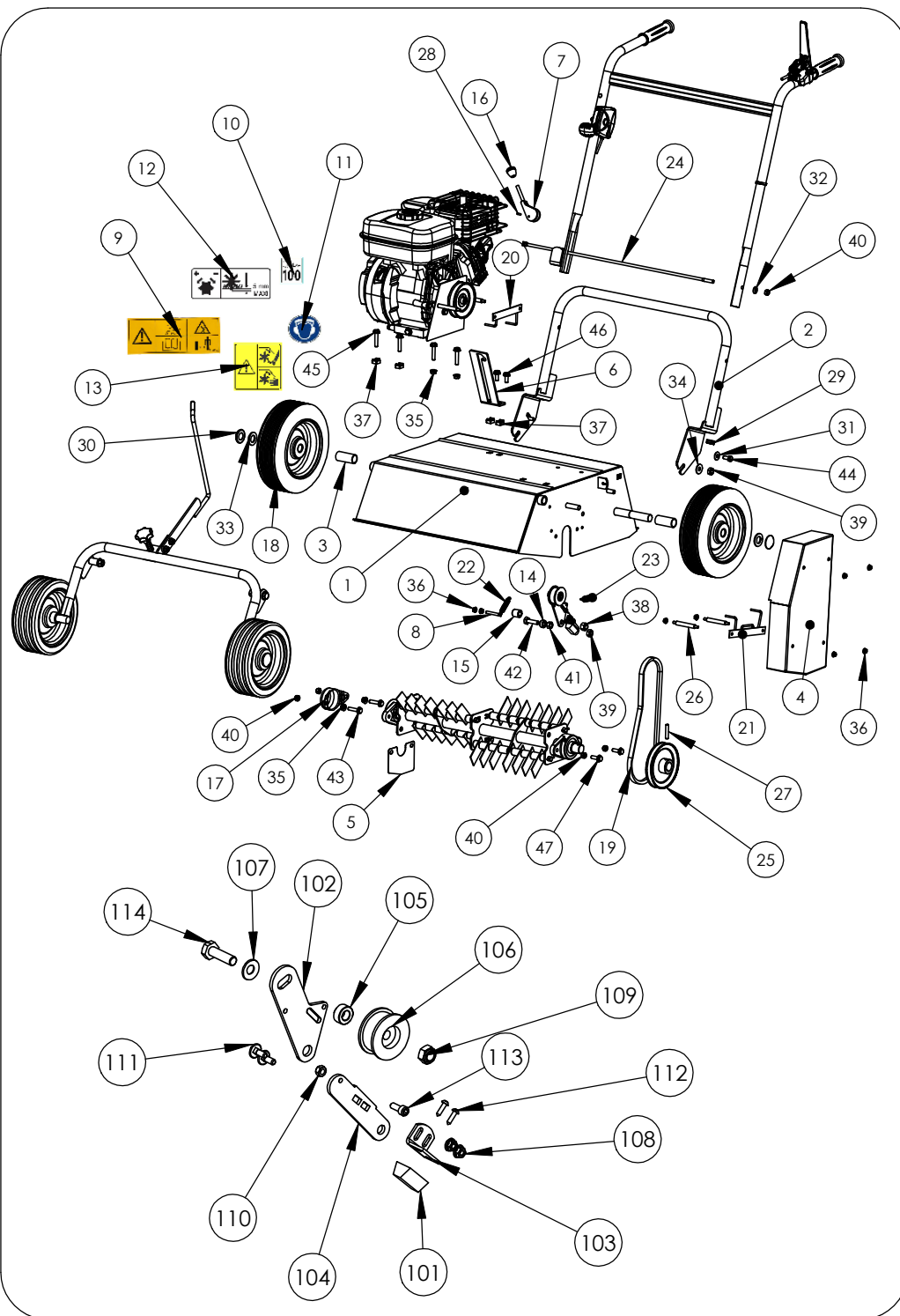

Rep N°	Ref.	Désignation	Description	Qté
1	534 100 228	CARTER SCARIF 50 ORANGE	ORANGE CARTER SCARIF 50	1
2	534 100 232	SUPPORT MANCHERON SCARIF 50 GRIS FONCE	DARK GRAY HANDLEBAR BASE	1
3	534 100 251	ENTRETOISE ROUE ARR SCARIF 50	ROUND SPACER FOR REAR WHEEL	2
4	534 100 192	CAPOT COURROIE SCARIF NOIR	BLACK BELT CARTER SCARIF	1
5	534 00 9752	PROTECTION CARTER SCARIF ZN NOIR	BLACK PROTECTIVE CARTER	1
6	534 100 182	SELECTEUR HAUTEUR SCARIF ZN	WORK LEVEL SELECTION TOOL	1
7	534 100 178	LEVIER VERROUILLAGE MANCHERON SCARIF ZN	HANDLEBAR LOCKING LEVER	1
8	534 00 6392	VIS BIELETTE EMBRAYAGE	CLUTCH SCREW	1
9	534 100 061	AUTOCOLLANT PRECAUTION D'EMPLOI	STICKER "CAUTION OF USE"	1
10	534 00 4611	AUTOCOLLANT 100 D.B.A.	STICKER 100 D.B.A.	1
11	534 100 285	AUTOCOLLANT CASQUE	STICKER "EARMUFF"	1
12	534 100 268	AUTOCOLLANT REGLAGE HAUTEUR DE COUPE	STICKER "HEIGHT ADJUSTMENT"	1
13	534 100 267	AUTOCOLLANT DANGER SECTIONNEMENT	STICKER "DANGER"	1
14	534 100 160	ENTRETOISE PLASTIQUE FREIN SCARIF	ROUND SPACER FOR BRAKES	1
15	534 100 161	ENTRETOISE LEVIER EMBRAYAGE SCARIF	ROUND SPACER	1
16	534 00 3585	BOULE PLASTIQUE NOIR DIAM 8	END PIECE Ø 8	1
17	534 00 9753	CACHE PALIER	BEARING COVER	1
18	534 00 9065	ROUE 250 X 85	WHEEL 250 X 85	2
19	534 100 241	COURROIE LA33	BELT LA33	1
20	534 100 314	PLAQUE DEBRAYAGE SUPERIEURE SCARIF	UPPER DECLUTCHING PLATE	1
21	534 100 313	PLAQUE DE DEBRAYAGE INFERIEURE	LOWER DECLUTCHING PLATE	1
22	534 100 246	RESSORT RAPPEL LEVIER EMBRAYAGE	SPRING	1
23	534 00 6390	RESSORT DE RAPPEL	SPRING	1
24	534 100 166	TRINGLE BLOCAGE MANCHERON SCARIF 50	HANDLEBAR LOCKING AXLE	1
25	534 100 282	POULIE ROTOR SCARIF 50	TRANSMISSION PULLEY SCARIF 50	1
26	534 100 162	AXE EPAULE FIXATION CAPOT	CARTER INSTALLATION AXLE	2
27	534 00 9061	GOUPILLE ROULEE 8 X 40	COTTER PIN 8x40 HBK	1
28	534 00 9062	GOUPILLE HBK 4 X 16	COTTER PIN 4x16 HBK	1
29	534 00 4793	PASSE FIL	WIRE PROTECT	1
30	534 100 023	ENJOLIVEUR Ø20	TRIM STOPPER	2
31	534 00 2478	RONDELLE CONTACT LARGE M8	LARGE WASHER M8	2
32	534 00 2014	RONDELLE CONTACT M8	WASHER M8	1
33	534 100 025	RONDELLE PLATE 20 X 36 X 3	PLATE WASHER 20 X 36 X 3	2
34	534 00 0724	RONDELLE PLATE 27 X 10.25 X 2 ZN	WASHER 27 x 10.25 x 2 ZN	2
35	534 100 020	ECROU H M8 EMB CR	NUT H M8 NOTCHED SHOULDER	4
36	534 100 008	ECROU H M6 Z EMB CR	NUT H M6 Z NOTCHED SHOULDER	8
37	534 00 4822	ECROU ' RAPID' DE 8 C4808 B	NUT RAPID M8 C 4808B	6
38	534 00 2484	ECROU FREIN M12	NUT BRAKE M10	1
39	534 00 1297	ECROU FREIN M10	BLOCKING NUT M10	3
40	534 00 3774	ECROU FREIN M8	BLOCKING NUT M8	5
41	534 00 0709	ECROU HU M10	NUT HU M10	1
42	534 00 0880	VIS HM 10 x 35	SCREW HM 10 x 35	1
43	534 00 9754	Vis HM 8x35 EMB CR	SCREW HM 8x35 notched shoulder	2
44	534 00 2209	VIS H M8 x 20 ZN	SCREW HM 8 x 20	2
45	534 100 266	VIS H EMB CR 8 x 40	SCREW H NOTCHED SHOULDER 8 X 40	4
46	534 100 019	VIS EMB CR 8 x 20	SCREW H NOTCHED SHOULDER 8 X 20	2
47	534 100 278	VIS H EMB CR 8 x 25	SCREW H NOTCHED SHOULDER 8 X 25	2

Rep N°	Ref.	Désignation	Description	Qté
101	534 100 253	FREIN ROTOR SCARIF	ROTOR'S BRAKE	1
102	534 100 184	LEVIER EMBRAYAGE SCARIF ZN	CLUTCH LEVER	1
103	534 100 190	EQUERRE FIXATION COURROIE DE FREIN PLIEE	FIXING BRAKE CARPENTER'S SQUARE	1
104	534 100 186	LEVIER FIXATION FREIN SCARIF TARAUDE	FIXING BRAKE PLATE	1
105	534 100 312	ENTRETOISE 10.5 x 20 x 9	ROUND SPACER 10.5 x 20 x 9	1
106	534 100 258	GALET EMBRAYAGE	CLUTCH PULLEY	1
107	534 00 1997	RONDELLE CONTACT M 10	WASHER M10	1
108	534 100 008	ECROU H M6 Z EMB CR	NUT H M6 Z NOTCHED SHOULDER	2
109	534 00 1297	ECROU FREIN M10	BLOCKING NUT M10	1
110	534 00 0992	ECROU HU M6	NUT HU M6	1
111	534 00 9079	VIS TRCC 6 x 16	SCREW TRCC 6 x 16	2
112	534 100 259	VIS TOLE TCL POZI 4.2 x 15.9 ZN	SCREW POZI DRIVE 4.2 x 15.9	2
113	534 00 4544	VIS CHC 6 x 16	SCREW CHC M6 x 16	1
114	534 00 0880	VIS HM 10 x 35	SCREW HM 10 x 35	1

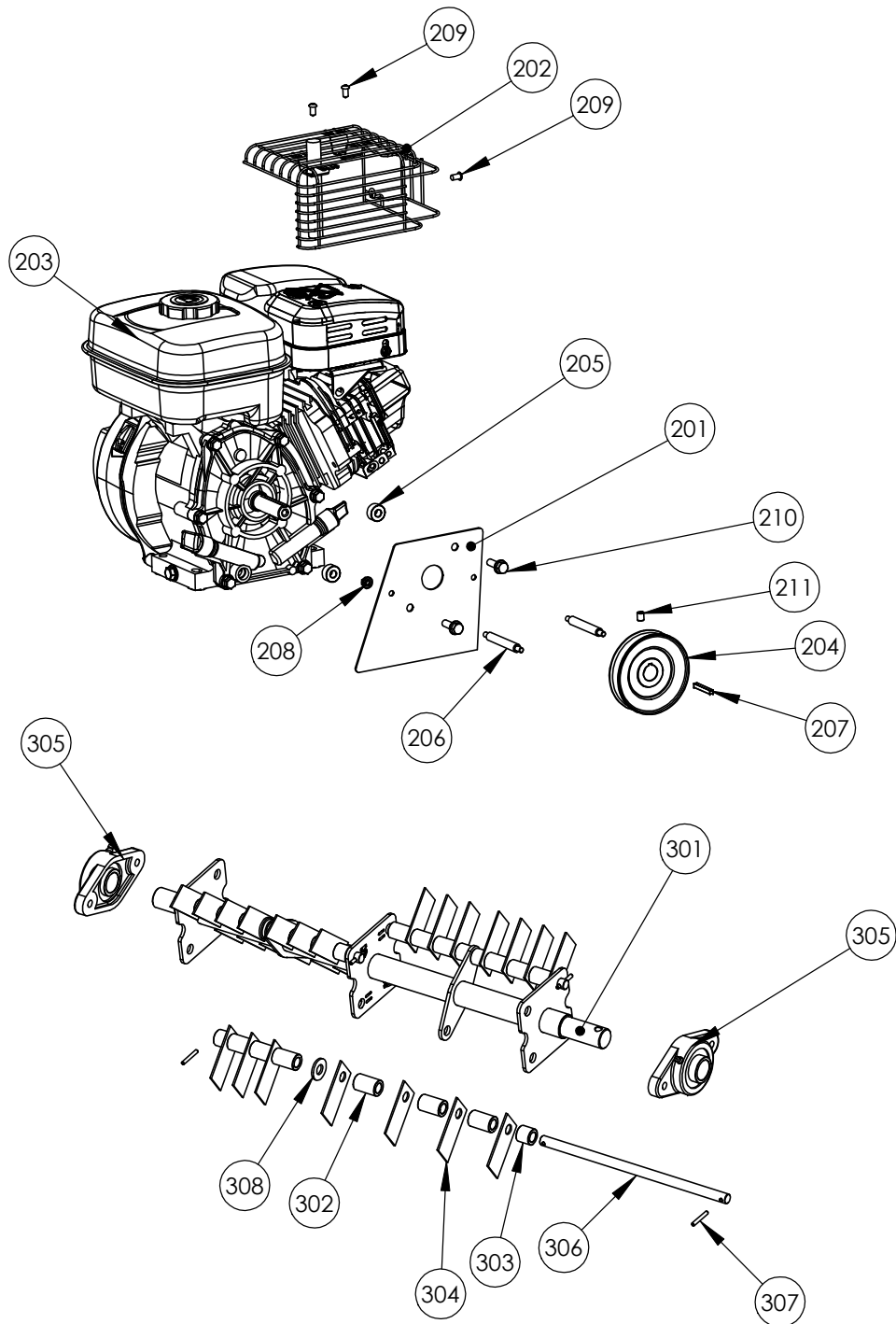

Rep N°	Ref.	Désignation	Description	Qté
201	534 100 194	TOLE PROTECTION POULIE MOTEUR SCARIF NOIR	CARTER FOR ENGINE'S PULLEY	1
202	534 00 9045	GRILLE ECHAPPEMENT EP	EXHAUST GRILL EP	1
203	534 00 9739	SUBARU EP 17 *	SUBARU EP 17*	1
204	534 100 169	POULIE MOTEUR	ENGINE'S PULLEY	1
205	534 100 154	ENTRETOISE TOLE PROTECTION SCARIF	ROUND SPACER	2
206	534 100 162	AXE EPAULE FIXATION CAPOT	CARTER INSTALLATION AXLE	2
207	534 00 4526	CLAVETTE B.DROIT 4.76 x 4.76 x 37	KEY 4.76 X 4.76 X 37	1
208	534 100 008	ECROU H M6 Z EMB CR	NUT H M6 Z NOTCHED SHOULDER	2
209	534 100 259	VIS TOLE TCL POZ 4.2 x 15.9 ZN	SCREW TCL POZ 4.2 X 15.9 ZN	3
210	534 00 3817	VIS TH EMB CR 5/16 LG 25 8.8 UNC	SCREW TH 5/16 X 25 NOTCHED SHOULDER	2
211	534 00 0421	VIS STHC 8 X 10 BOUT CUVETTE	SCREW STHC 8 X 10	1

* Le service après vente moteur : S'adresser au réseau motoriste concerné.

* Obvious guarantee : Contact the motorist sales network

Rep N°	Ref.	Désignation	Description	Qté
301	534 100 318	ROTOR RENFORCE SCARIF 50	ROTOR AXLE	1
302	534 100 320	ENTRETOISE PLASTIQUE 12.2 x 20 x 31	ROUND SPACER 12.2 x 20 x31	24
303	534 100 319	ENTRETOISE PLASTIQUE 12.2 x 20 x 18	ROUND SPACER 12.2 x 20 x 18	8
304	534 100 163	COUTEAUX MOBILES SCARIF	KNIVES	28
305	534 100 172	PALIER FONTE DIAM=25	SELF - ALIGNING BEARING UNIT	2
306	534 100 155	AXE FIXATION COUTEAUX MOBILES SCARIF 50	KNIVES AXLE	4
307	534 00 9751	GOUPILLE HBK 4 X 30	ROLLED COTTER 4 x 30	8
308	534 00 1286	RONDELLE PLATE 27 x 12.5 x 2.5	WASHER 27 x 12.5 x 2.5	4

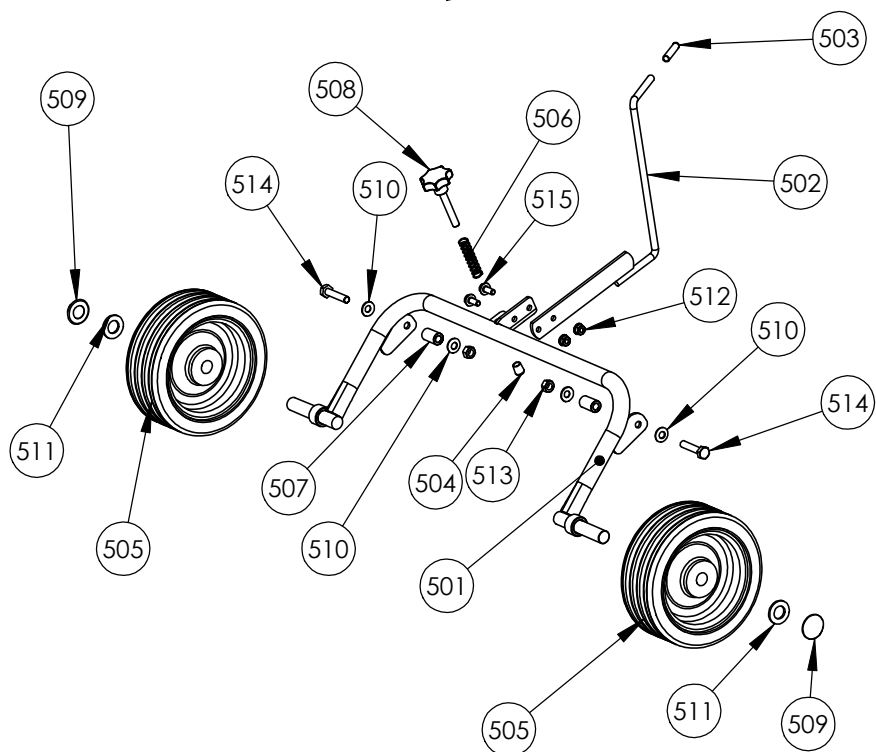
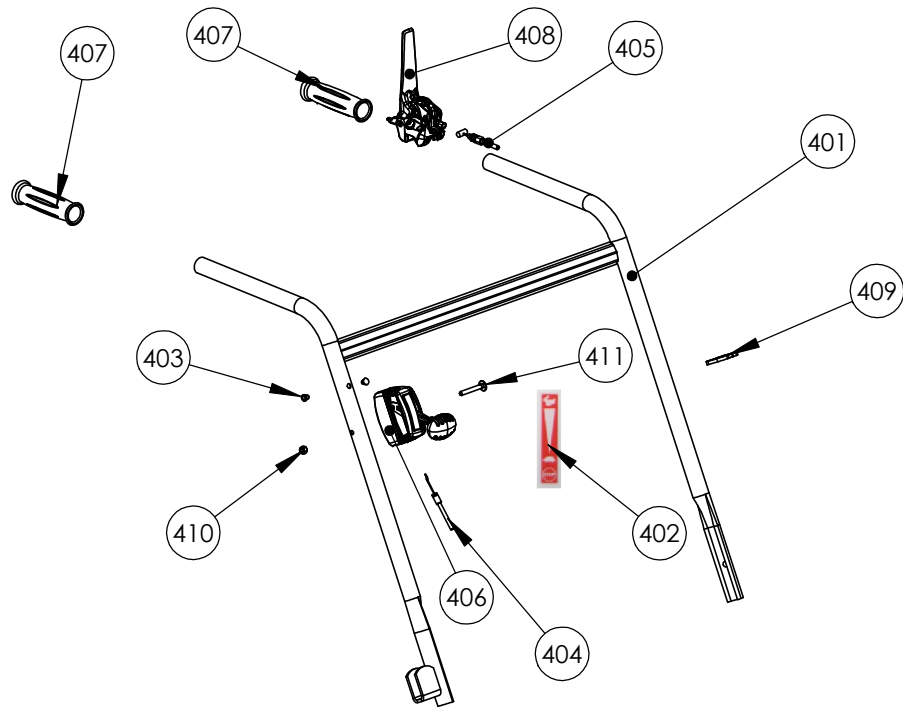

Rep N°	Ref.	Désignation	Description	Qté
401	534 100 240	MANCHERON SCARIF 50 GRIS FONCE	DARK GRAY HANDLEBAR SCARIF 50	1
402	534 100 265	AUTOCOLLANT ACCELERATEUR STOP SANS STARTER	STICKER "ENGINE SPEED VARIATION" WITHOUT STARTER	1
403	534 100 021	OBTURATEUR 10 x 7 x 6.5	CAP 10 X 7 X 6.5	2
404	534 00 9737	CABLE COMMANDE DES GAZ	THROTTLE CABLE	1
405	534 00 9711	CABLE EMBR ROTOR SCARIF	CLUTCH CABLE	1
406	534 00 9736	POIGNEE GAZ	THROTTLE LEVER	1
407	534 100 054	POIGNEE CAOUTCHOUC DIAM 25	GRIP	2
408	534 00 9709	LEVIER EMBRAYAGE	CLUTCH LEVER	1
409	534 00 9120	COLLIER PLASTIQUE NOIR	BLACK COLLAR	4
410	534 00 4265	ECROU FREIN H M6	BLOCKING NUT M6	1
411	534 00 9744	BOULON TRCC 6 x 45	SCREW TRCC 6 X 45	1

Rep N°	Ref.	Désignation	Description	Qté
501	534 100 236	TRAIN AVANT SCARIF GRIS FONCE	DARK GRAY FRONT AXLE SCARIF	1
502	534 100 175	LEVIER DE RELEVAGE SCARIF SOUDE	LIFT HANDLE	1
503	534 100 243	EMBOUT PLASTIQUE DIAMETRE 9 x 50	END PIECE LENGTH : 50	1
504	534 100 144	EMBOUT ROND ENVELOPPANT	PLASTIC CAP	1
505	534 00 9064	ROUE 208 X 80	WHEEL 208 X 80	2
506	534 100 145	RESSORT POIGNEE REGLAGE HAUT	SPRING	1
507	534 00 6016	ENTRETOISE ARTICULATION	ROUND SPACER	2
508	534 100 242	MOLETTE REGLAGE HAUT. M10	HEIGHT LEVEL ADJUSTMENT	1
509	534 100 023	ENJOLIVEUR Ø20	TRIM STOPPER	2
510	534 00 1997	RONDELLE CONTACT M 10	WASHER M10	4
511	534 100 025	RONDELLE PLATE 20 X 36 X 3	PLATE WASHER 20 X 36 X 3	2
512	534 100 020	ECROU H M8 EMB CR	NUT H M8 NOTCHED SHOULDER	2
513	534 00 0709	ECROU HU M10	NUT HU M10	2
514	534 00 6041	VIS TH 10 x 50 ZN	SCREW TH 10 X 50 ZN	2
515	534 100 019	VIS EMB CR 8 x 20	SCREW H NOTCHED SHOULDER 8 X 20	2